

Temperature Sensor

Model: WN1821&WN1820

Contents

1. Feature	3
2. Display Console	5
3. Screen Display	8
4. Key Function	10
5. Modes	14
5.1 Normal Mode	14
5.2 Alarm Clock Hour-Setting Mode	15
5.3 Alarm Clock Minute-Setting Mode	15
5.4 MAC Address Display Mode	16
5.5 Setting Mode	16
6. Display Console	18
6.1 List of sensors that can be displayed on the screen	18
6.2 CO ₂ Concentration	19
6.3 CO ₂ Calibration	20

6.4 Wi-Fi Icon	21
6.5 Host Battery Low Voltage Icon	22
7. Live Internet Publishing	23
7.1 Wi-Fi Configuration	24
7.1.1 Wi-Fi Configuration via Web Page	24
7.1.2 Configure Device on Ecowitt APP	27
8. Backlight	29
9. Alarm Clock	30
9.1 Alarm Clock Function	30
9.2 Snooze Function	30
10. Trend Arrow Function	31
11. RF Reception Function	32
12. Storage Function	35
13. Cloud Functions	36
14. Specification	38



- * Please scan the QR code to read English manual and keep it for future reference
- * Bitte scannen Sie den QR-Code zudeutsche Anleitung lesen und aufbewahren fürZukunftsbezug
- * Si prega di scansionare il codice QR perleggi il manuale italiano e conservalo perReferenza futura

Instruction manuals

<https://s.ecowitt.com/YKMQNM>



MADE IN CHINA



OASIS SERVICE SP. Z O.O. ul.
Młynarska 42 lok.115
01-171 Warszawa



HUA TENG LIMITED
3 Glass Street, Hanley, Stoke On Trent,
ST1 2ET United Kingdom

Help

Our product is continuously changing and improving, particularly online services and associated applications. To download the latest manual and additional help, please contact our technical support team:

support@ecowitt.com

support.eu@ecowitt.net (EU/UK)

1. Feature

1. WN1821 has built-in Photoacoustic NDIR CO₂ Sensor for detecting CO₂ concentration, while WN1820 can work with WH45 Transmissive NDIR CO₂ detection, or WH46 Photoacoustic NDIR CO₂ to activate CO₂ function. Both of display has built-in temperature and humidity, and air pressure.
2. Support displaying indoor temperature humidity and the changing trend; support displaying outdoor multi-channel transmitter temperature humidity and the changing trend.
3. Support receiving and displaying multi-channel temperature and humidity sensor/transmitters, such as WN31, WN34, WN35, WH51.
4. Can be used as a Wi-Fi gateway to support the reception of more sensors' data, which can be viewed via the web.

5. Maximum/minimum data logging.
6. Supports Wi-Fi configuration on web page, viewing more sensors' data, setting server, setting calibration parameters, setting Sensor ID.
7. With Wi-Fi function, supports for uploading data to the weather station server.
8. Automatic time zone and automatic network time acquisition.
9. Supports unit setting.
10. DC power supply, supports backlight brightness adjustment.

2. Display Console



Figure 1

- (1) Unfold the desk stand and place the console 5 to 10 feet away from the outdoor sensor.

- (2) Remove the battery door on the back of the console and insert 2 x AA good quality Alkaline or Lithium batteries per.
- (3) Wait several minutes for the remote sensors to synchronize with the display console.
- (4) In order to prevent the display console's own temperature rising from affecting the accurate reading of temperature and humidity, the temperature and humidity sensor is placed at the antenna end, away from the station body. Orient the console antenna straight up for accurate indoor temperature and humidity reading.

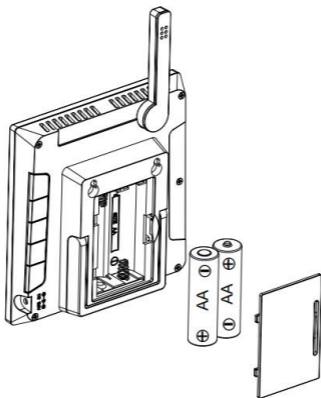

Figure 2

3. Screen Display

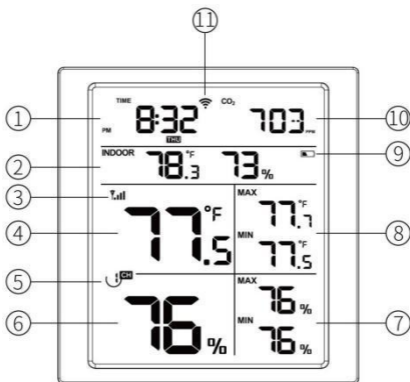

Figure 3

- ① Time
- ② WH51 Soil moisture, WN34 soil/liquid temperature sensor, WN35 leaf wetness sensor

- ③ Signal Icon
- ④ WN31 Temperature (WN31 Need to Separately Purchase)
- ⑤ Channel Number
- ⑥ WN31 Humidity (WN31 Need to Separately Purchase)
- ⑦ WN31 MAX & MIN Humidity (WN31 Need to Separately Purchase)
- ⑧ WN31 MAX & MIN Temperature (WN31 Need to Separately Purchase)
- ⑨ Power Status
- ⑩ CO₂ PPM Level/Date
- ⑪ Wi-Fi Icon

4. Key Function

The console has five keys for easy operation

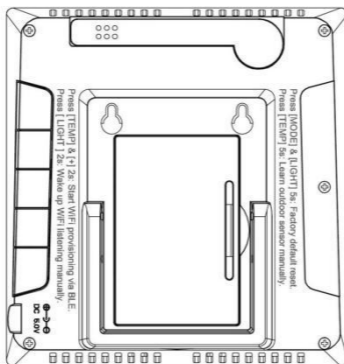
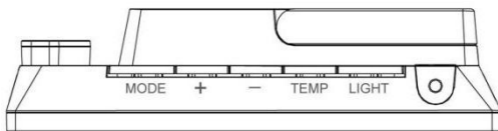

【MODE】 :

- (1) Press to switch between Normal Mode, Alarm Clock Hour-Setting Mode, Alarm Clock Minute-Setting Mode, MAC Address Display Mode.
- (2) Press and hold for two seconds to enter the Set Mode.

【+】 :

- (1) While in Normal Mode, press this button to switch between date, CO₂, CO₂24hAVG, CO₂1hMAX, CO₂24hMAX and CO₂MAX.
- (2) While displaying the CO₂24hAVG/1hMAX/24hMAX/MAX, long press this button to reset max data.

【-】 : Activate this function after turning on the indoor display area under the settings mode.

- (1) While in Normal Mode, press this button to switch between Indoor, WN34 CH1, WN34 CH2, WN34 CH3, WN34 CH4, WN34 CH5, WN34 CH6, WN34 CH7, WN34 CH8, WN35 CH1, WN35 CH2, WN35 CH3, WN35 CH4, WN35 CH5, WN35 CH6, WN35 CH7, WN35 CH8, WH51 CH1, WH51 CH2, WH51 CH3, WH51 CH4, WH51 CH5, WH51 CH6, WH51 CH7, WH51 CH8, \cup , INDOOR.
- (2) While in single channel of the above operation, long press this button 5 seconds to re-register the corresponding CH sensor.
- (3) While in \cup mode, long press this button 5 seconds to re-register the WN34/WN35/WH51 CH1~8 sensors.

【TEMP】 :

- (1) While in Normal Mode, press this button

to switch WN31 area displaying content, the sequence is from WN31 CH1, WN31 CH2, WN31 CH3, WN31 CH4, WN31 CH5, WN31 CH6, WN31 CH7, WN31 CH8, \cup .

- (2) While in single WN31 CH mode, long press this button 5 seconds to re-register the corresponding CH sensor.
- (3) While in \cup mode, long press this button 5 seconds to re-register WN31 CH1~8 sensor.

【Light】 :

When powered by DC, press this button to switch between High, Middle, Low, Off.

Combination Button

MODE/Light: long press these 2 buttons at the same time for 5 seconds to restore factory settings and reboot.

+ /TEMP: long press these 2 buttons at the same time over 2 seconds to trigger Soft-AP and the Wi-Fi icon will fast flash; you can use PC or phone to connect its hot spot.

5. Modes

There are 5 modes : Normal Mode, Setting Mode, Alarm Clock Hour-Setting Mode, Alarm Clock Minute-Setting Mode, MAC Address Display Mode.

5.1 Normal Mode

While normally power on, the device enter into the normal mode in default. While in other modes, the device will automatically enter into the normal mode after 30 seconds no operation or press the button LIGHT (Not hold) to enter

into normal mode.

5.2 Alarm Clock Hour-Setting Mode

1. While in Alarm Clock Hour-Setting Mode, Adjust the hour by pressing the button + and - .
2. Power on/off the alarm clock by pressing the button TEMP .

5.3 Alarm Clock Minute-Setting Mode

1. While in Alarm Clock Minute-Setting Mode, Adjust the minute by pressing the button + and - .
2. Power on/off the alarm clock by pressing the button TEMP .

5.4 MAC Address Display Mode

Press the button **MODE** to enter the MAC Address Display Mode to check the mac address.

5.5 Setting Mode

Press and hold the **MODE** button for two seconds to enter the Setting Mode. To proceed to the next setting, press (do not hold) the **MODE** button.

To exit the SET mode at any time, press the **LIGHT** button.

Summarizes the set mode sequence and commands.



Command	Mode	Settings
[MODE] + 2 seconds	Enter Setting Mode, Beep On or Off	Press [+] or [-] to switch OFF and ON. This will prevent the beep



		from sounding when pressing any button.
[MODE]	Clear Max/Min	Press [+] or [-] to switch OFF and ON. When set to ON, the minimum and maximum values reset every day at midnight (00:00). When set to OFF, the minimum and maximum values must be reset manually.
[MODE]	Indoor display area	Press [+] or [-] to adjust on or off.
[MODE]	12 hour / 24 hour Format	Press [+] or [-] to switch hour format between 12 hour and 24-hour format.
[MODE]	Hour	Press [+] or [-] to adjust hour up or down.
[MODE]	Minute	Press [+] or [-] to adjust minute up or down.
[MODE]	Year	Press [+] or [-] to adjust year up or down.
[MODE]	Month	Press [+] or [-] to adjust month up or down.
[MODE]	Day	Press [+] or [-] to adjust day

		up or down.
[MODE]	Temperature Units of Measure	Press [+] or [-] to change temperature units of measure between °F and °C.
[MODE]	CO ₂ Calibration	Press [TEMP] to switch OFF and ON.

6. Display Console

6.1 List of sensors that can be displayed on the screen

Item Number	Number of Channels	Description	Image
WN31	8	Multi-Channel Thermometer and Hygrometer Sensor	
WH51	8	Wireless Soil Moisture Sensor	

WN35	8	Leaf wetness sensor	
WN34	8	WN34S stainless-steel probe thermometer for soil WN34L wire probe thermometer for water	

6.2 CO₂ Concentration

1. If device detects the built-in CO₂ concentration sensor, it will automatically switch to display the real-time CO₂ concentration value when the product is powered up and detect the CO₂ concentration.
2. While in Normal Mode, press this button to switch between date, CO₂ live data, CO₂ 24hAVG, CO₂ 1hMAX, CO₂ 24hMAX and CO₂ MAX.

6.3 CO₂ Calibration

In Normal Mode, hold the button Mode 2 seconds to enter into the Setting Mode, and press the button Mode until CO₂ calibration mode is presented. Put the console in outdoor air location, or at least with normal fresh outdoor air submerged.

1. Display real-time CO₂ concentration data, updates once every 5 seconds.
2. When "ON" flashes to indicate that CO₂ calibration is currently in progress; when "OFF" flashes to indicate that CO₂ calibration is not currently in progress. Default value 420PPM will be displayed. Adjust this value if you have other reliable reference reading available.
3. Before calibration is completed, the calibration value can be adjusted by pressing the button.
4. After calibration, "OK" flashes to indicate

successful CO₂ calibration; when "NG" flashes to indicate failure of CO₂ calibration.

5. In the CO₂ calibration page, it will not return to the main page automatically.

6.4 Wi-Fi Icon

Wi-Fi Icon	State
Fast Flash	Soft-AP switched on after power up or key activation
Solid OFF	Device lost connection with the router
Slow Flash	Device successfully connects with the router
Solid ON	Data has been uploaded to the server. The Wi-Fi icons indicate signal strength and are divided into 5 levels, corresponding to the icons 0 frame, 1 frame, 2 frame, 3 frame and 4 frame. 0 frame: no wifi connection 1 frame: $RSSI < -85$ 2 frames: $-85 \leq RSSI < -75$ 3 frames: $-75 \leq RSSI < -65$

6.5 Host Battery Low Voltage Icon

1. The display will show the low voltage icon if no batteries are presented on console.
2. When the battery voltage of the device is less than or equal to 2.5V, the low voltage icon will be displayed.
3. If the device's battery is higher than 2.5V, the low voltage icon will not be displayed (when recovering from low voltage, it needs to be above 2.6V before the low voltage icon will not be displayed).
4. The battery is purely for backup purpose, and with battery power, the device can work for 24hours.

7. Live Internet Publishing

Your console is capable of sending your sensor data to different cloud weather services. The supported services are shown in the table below:

Hosting Service	Website	Description
Ecowitt Weather		Ecowitt is a new weather server that can host a bunch of sensors that other services don't support.
Weather Underground	WeatherUnderground.com	Weather Underground is a free weather hosting service that allows you to send and view your weather station data real-time, view graphs and gauges, import text data for more detailed analysis and use iPhone, iPad and Android applications available at Wunderground.com. Weather Underground is a subsidiary of The Weather

		Channel and IBM.
Weather Cloud	WeatherCloud.net	Weathercloud is a real-time weather social network formed by observers from around the world
Weather Observation Website (WOW)	http://wow.metoffice.gov.uk/	WOW is a UK based weather observation website. WOW allows anyone to submit their own weather data, anywhere in the world.
Customized Website		Supports uploading to your customized website, if the website has the same protocol with Wunderground or Ecowitt

7.1 Wi-Fi Configuration

7.1.1 Wi-Fi Configuration via Web Page

1. Turn on Soft-AP

The device will automatically turn on Soft-AP when powered on. If the product is

not configured Wi-Fi, the Soft-AP of this device will always be on and the Wi-Fi icon flashing indication. You can also press “+/TEMP” button at the same time for 2s to activate this Soft-AP broadcasting.

2. PC or mobile phone connect to this device's Soft-AP

e.g. WN18xx-WIFIxxxx, x stands for the product model, xxxx stands for the last 4 digits of the product MAC address. To prevent phone switching back to cellular network, please switch off your phone cellular data service, which can prevent many unknown problems.

3. Open your browser and visit 192.168.4.1
Enter into the login page and there is no password needed, directly click Login.
4. Select the Local Network
5. Select Scan Router, then select the router

that to be connected to

6. Enter your router password and click “Apply” to save the inputs
7. When successfully connected with the router, a success message will be prompted
8. Complete the Wi-Fi configuration

You may come back to this embedded web page anytime with the newly assigned IP address. Sensor management, sensor calibration, live data etc. can be all handled here.

9. Make the MAC address (on this web page or via console key operation), you can register on www.ecowitt.net. Under “menu” - “device” page, you can add a new device with the Mac address directed to this device.
10. Install “ecowitt” app, log in and your weather station data will be populated

accordingly.

7.1.2 Configure Device on Ecowitt APP

Beside accessing the Soft-AP method through its embedded web page management, you can also complete your account register, device wifi provisioning and account binding with the help of “ecowitt” APP. The APP will walk you through the complete setup. Please make sure your phone has cellular network service turned off, “ecowitt” APP is allowed for precise location service and WiFi service.

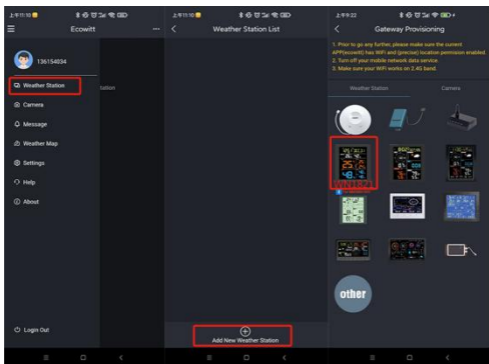

1. Install “ecowitt” app. Make sure you have the app with location and wifi service enabled.
2. Turn off your mobile phone “cellular network” data service during the setup process (if it is a mobile phone running the ecowitt app).
3. Tap “menu” at the top left corner –

“weather station” – “+ add a new weather station” to start the wifi provisioning process.

4. Follow the instruction from the app, and if there is still a problem, please send me a screen shot with the problem.

8. Backlight

- * When powered by batteries, the backlight will turn off after the product is powered on 15s.
- * When powered by batteries, the backlight will on by pressing any button, and the backlight will turn off automatically after 15s of no button operation.
- * When powered by DC power supply, the backlight will be automatically adjusted to medium.
- * After disconnecting with DC power supply,

the brightness will maintain for 15s and then automatically turn off.

- * When powered by DC power supply, short press LIGHT to adjust the backlight: High -> Medium -> Low -> Off.

9. Alarm Clock

9.1 Alarm Clock Function

After the alarm is triggered, the alarm will continue to ring for 2 mins without any button operation, and the alarm will ring more and more rapidly during the 2 mins.

9.2 Snooze Function

- * When you set the alarm and it is triggered, short press LIGHT to enter snooze mode and the icon will be displayed at the alarm. 10

minutes later the alarm will sound again.

- * Press and hold any button for 2 seconds after entering snooze mode to exit snooze mode.

10. Trend Arrow Function







- * Only indoor temperature and humidity, WN31 WN34 temperature and humidity have the trend arrow function.
- * The algorithm is as follows :
3 hrs comparison which changes on every ½ hour
Eg.: At 3:00 - compare to 12:00 data; at 3:30 -compare to 12:30 etc







Tendency indicators	Humidity	Temperature
▲	Rising > 3%	Rising >= 1C/2F
▼	Falling > 3%	Falling >= 1C/2F

11. RF Reception Function

- * The RF icon will decrease the signal by one frame if data is not received from a registered sensor; if data is received, the RF icon will increase the signal by one frame.
- * The RF reception function will always be on to receive data from multiple sensors at any time. With WSVIEW Plus APP and Ecowitt APP, you will get more powerful data service functions.
- * When powered by DC supply, the device supports these sensors as below:

Sensor Model	Quantity	Picture	Function
WS90	1		Haptic rain sensor, ultrasonic wind speed and direction, temperature and humidity, light UV transmitter, 4.75s once Family Code = 0x80 Start wind speed 0.5m/s

WH65/ 69/67	1		Outdoor temperature and humidity, light UV, wind speed and direction, rainfall
WS68	1		Wind speed and direction, light UV
WH40	1		Rainfall
WS80	1		Ultrasonic wind speed and direction, UV light, outdoor temperature and humidity
WH57	1		Lightning detection
WH45	1		CO ₂ , PM2.5, PM10, temperature and humidity

WH41/ 43	4		PM2.5
WH55	4		Water leaking detection
WN31/ WN30/ WN36	8		WN31 thermometer and hygrometer WH30 thermometer WN36 pool thermometer
WH51	8		Soil moisture
WN34	8		thermometer
WN35	8		Leaf wetness sensor

12. Storage Function

- * Once powered on, the device will save the changed settings after 3 mins, and the product will restore the previous setting items when re-powered.
- * If you change the setting parameters via its embedded web page, it will save them immediately and the settings will not be lost when powered off.
- * The following settings can be saved:
 1. Turn on/off the alarm clock, set the hour and minute of the alarm clock.
 2. BEEP on/off status.
 3. RST daily maximum/minimum on/off.
 4. 12/24H hour format.
 5. Temperature unit setting.
- * After the device completes upgrade it will save the built-in CO₂ , WN31 1~8 maximum and minimum value data, including:

1. MAX, 1H MAX, 24H MAX, 24H AVG for CO₂ .
 2. WN31 1~8 MAX/MIN temperature and humidity.
- * After finishing CO₂ calibration, the CO₂ calibration value will be saved in the NVS, and the next power-up will read the latest CO₂ calibration value after a successful calibration.

13. Cloud Functions

- * Only after Wi-Fi configuration can use the upload function.
- * Weather servers support below servers after successful Wi-Fi configuration:
 - A. Ecowitt.net
 - B. Wunderground
 - C. Weathercloud

D. Weather Observations Website

E. Custom server

- * Automatically get the network time every hour automatically.
- * If you have set up automatic firmware updates on the web page, every time a new firmware is available, the product goes into OTA and the "OTA" character and the update progress are displayed on the screen. After a successful automatic firmware update, "OTA OK" is displayed and the product is automatically rebooted. (The automatic update interval is 24 hours).

14. Specification

Model:WN1821

Name	: Weather Station (receiver)
Dimensions	: 110×104.5×27.5 (mm)
Screen Size	: 80.5×96 (mm)
Weight	: 160 (g)
Material of Plastic Casing	: ABS
Material of Screen	: VA-LCD
Temperature Metering Range	: -9.9°C to 60°C (14°F to 140°F)
Temperature Metering Accuracy	: ±0.2°C (±0.4°F)
Temperature Metering Resolution	: 0.1°C (0.2°F)
Humidity Metering Range	: 1%RH to 99%RH
Humidity	

Metering Accuracy	: $\pm 2\%RH$
Humidity Metering Resolution	: $1\%RH$
Barometric Pressure Metering range	: 300 to 1100 hPa (8.85 to 32.5 inHg)
Barometric Pressure Metering accuracy	: $\pm 1.5hpa$ (absolute pressure); $\pm 2hpa$ (relative pressure)
Barometric Pressure Metering resolution	: 0.1 hPa (0.01 inHg)
Photoacoustic NDIR CO ₂ Metering range	: 0 to 40000ppm
Photoacoustic	

NDIR CO ₂ Metering accuracy	: ±(50ppm + 5% of reading) when 400 to 2000 ppm
Photoacoustic NDIR CO ₂ Metering resolution	: 1ppm
Photoacoustic NDIR CO ₂ Accuracy drift per year	: ± (5ppm + 5% of reading)
Reading Update Interval	: About 1 minute
RF Connection Frequency	: 920/915/868/433MHz (depending on local regulations)
RF Wireless Range	: Over 100 meters (in open areas)
WLAN	: 802.11 b/g/n 2.4 GHz (802.11n, Max 150 Mbps)
WLAN Range	: Over 30 meters (in open areas)

Console	
Operating	
Temperature	: -10°C to 50°C (14°F to 122°F)
Power Supply	: 5V DC or 2×1.5V AA Battery (not included)
Battery Life	: 1 day

Model:WN1820

Name	: Weather Station (receiver)
Dimensions	: 110×104.5×27.5 (mm)
Screen Size	: 80.5×96 (mm)
Weight	: 158.3 (g)
Material of	
Plastic Casing	: ABS
Material of	
Screen	: VA-LCD
Temperature	
Metering	
Range	: -9.9°C to 60°C (14°F to 140°F)
Temperature	
Metering	
Accuracy	: ±0.2°C (±0.4°F)

Temperature
Metering
Resolution : 0.1°C (0.2°F)

Humidity
Metering
Range : 1%RH to 99%RH

Humidity
Metering
Accuracy : ±2%RH

Humidity
Metering
Resolution : 1%RH

Barometric
Pressure
Metering
range : 300 to 1100 hPa (8.85 to 32.5
inHg)

Barometric
Pressure
Metering
accuracy : ±1.5hpa (absolute pressure);
±2hpa (relative pressure)

Barometric
Pressure

Metering resolution	: 0.1 hPa (0.01 inHg)
Reading Update Interval	: About 1 minute
RF Connection Frequency	: 920/915/868/433MHz (depending on local regulations)
RF Wireless Range	: Over 100 meters (in open areas)
WLAN	: 802.11 b/g/n 2.4 GHz (802.11n, Max 150 Mbps)
WLAN Range	: Over 30 meters (in open areas)
Console Operating Temperature	: -10°C to 50°C (14°F to 122°F)
Power Supply	: 5V DC or 2×1.5V AA Battery (not included)
Battery Life	: 1 day

What types of NDIR sensors exist and how do they work?

An introduction to the principles behind transmissive and photoacoustic NDIR sensing
Characteristics of NDIR Sensors:

NDIR sensing has become the prevalent technique for measuring CO₂ concentration. The technology exploits the characteristic property of CO₂ molecules to strongly absorb infra-red (IR) light with wavelengths around 4.2 μm. When shining light of this wavelength through a gas sample, the CO₂ concentration can thus be calculated from the proportion of light that is absorbed.

It is important to note that NDIR sensors do not require a dispersive element, such as a prism or a diffraction grating, to discriminate for the targeted wavelength. Instead, the light produced by the emitter is shown through a non-dispersive band-pass filter, allowing only

the infrared wavelengths of interest to pass. These characteristics give the sensors their classification: Non-dispersive Infra-red.

Transmissive NDIR:

These NDIR sensors typically feature an IR emitter and an optical detector, such as a photodiode, at opposite ends of a specially designed optical cavity. The optical detector measures the amount of IR light energy that is not absorbed by (i.e., transmitted through) the gas sample.

As the CO₂ concentration in the optical cavity increases, the amount of light detected decreases. Hence, this principle determines the amount of light energy CO₂ molecules have absorbed by calculating the difference between the measurement and a reference intensity at a known CO₂ concentration.

NDIR CO₂ sensors leverage infra-red

absorption at 4.2 μm wavelength without the use of dispersive optical elements.

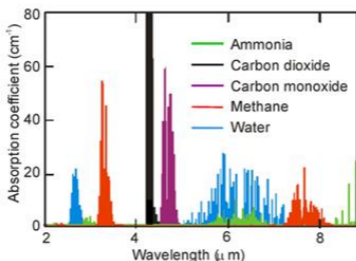

Absorption spectra of common trace gases
(HITRAN2016 molecular spectroscopic database)

Note that this reference value heavily depends on precise positioning of IR emitter and photodetector, as well as the emission properties of the IR source and the optical cavity. Mechanical and thermal stresses acting

on the measurement chamber can thus significantly falsify CO₂ readings.

Furthermore, transmissive NDIR sensors generally require a minimal optical path length in the centimeter scale for enough IR absorption to occur to accurately measure lower CO₂ concentrations.

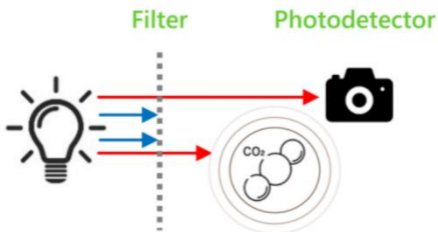

Illustration of a Transmissive NDIR setup

Photoacoustic NDIR:

In contrast to transmissive NDIR sensors, photoacoustic NDIR sensors detect the amount of energy that is absorbed by CO₂ molecules. When pulsing the infra-red emitter, CO₂ molecules absorb infra-red light periodically. This causes additional molecular vibration resulting in a pressure wave inside the measurement chamber. The higher the CO₂ concentration, the more light is absorbed, and thus the greater the amplitude of this acoustic wave becomes. A microphone inside the gas chamber measures this, from which the CO₂ concentration can then be calculated.

Photoacoustic NDIR sensing allows for much greater miniaturization of the measurement chamber. Furthermore, as sound waves are omnidirectional, relative positioning of emitter and microphone is unconstrained. Thus, photoacoustic NDIR sensors are usually more mechanically and thermally robust.

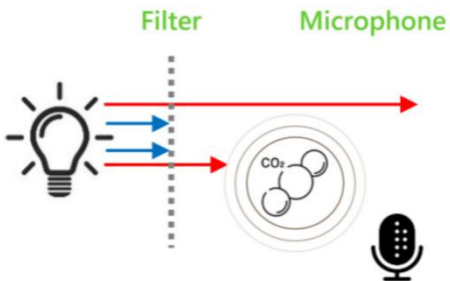

Illustration of a Photoacoustic NDIR setup